



APPLICATION

The V160-10G tubes are provided with a hooded copper anode incorporating a low inherent filtration beryllium window. This design effectively reduces glass wall charges as well as stray radiation by intercepting secondary electrons. The result is better stability over the life of the tube and greater contrast in x-ray images. The V160-10G also utilizes a special isolated cathode that allows grid control of the tube current.

PRODUCT DESCRIPTION

STRUCTURE

Cathode:	Tungsten filament, line source
Focal Spot Size:	D = 2.5
Inherent Filtration:	.8 mm Be, 1.5 mm glass
Target Angle:	10°
X-Ray Coverage:	20°
Weight:	2 lbs. (1kg)

RATINGS

Maximum:	160 kVp Maximum
Voltage:	
Current:	2.0 mA Continuous
Anode Heat Storage:	150,000 HU
Power:	320 Watts Continuous
Filament:	5.3 V and 4.4 A Typical 5.0 Amps Maximum
Grid Control Voltage:	See chart
Grid Pulse Rating:	See chart
Emission:	See chart

COOLING AND INSULATION

Oil: Circulated high grade transformer oil with a standard gap (ASTM D 877) dielectric strength of 45 Kvp.

Gas: Sulfur Hexafluoride, 30 to 45 lbs. per square inch; pressure not to exceed 60 lbs. per square inch during operation.

Maximum operating temperature; 70°C oil; 65°C gas.

Caution: High voltage should be applied gradually in steps if tube has been out of service for a lengthy period of time.

V160-10G

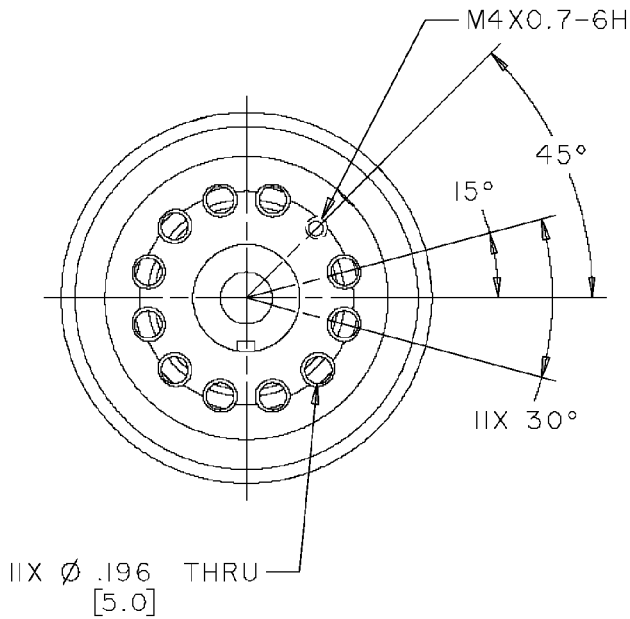
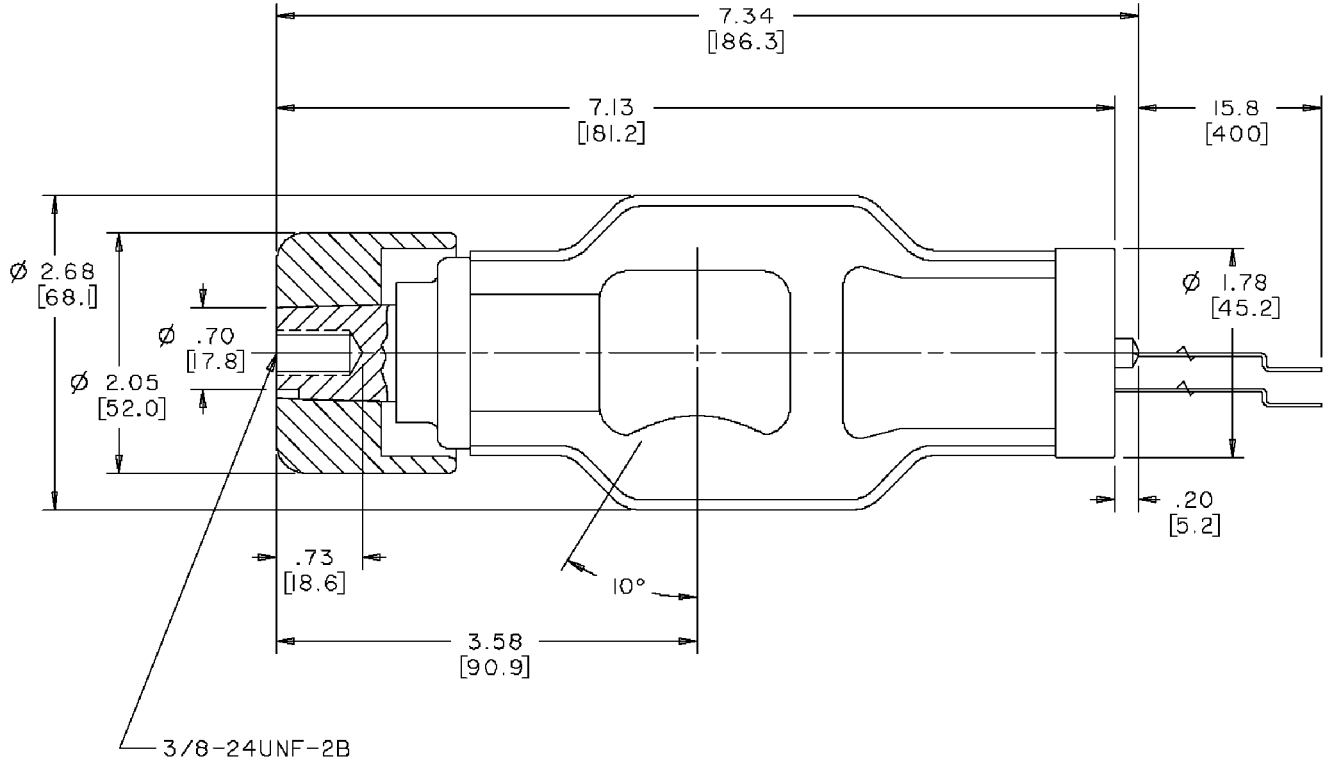

WIRING CONNECTIONS

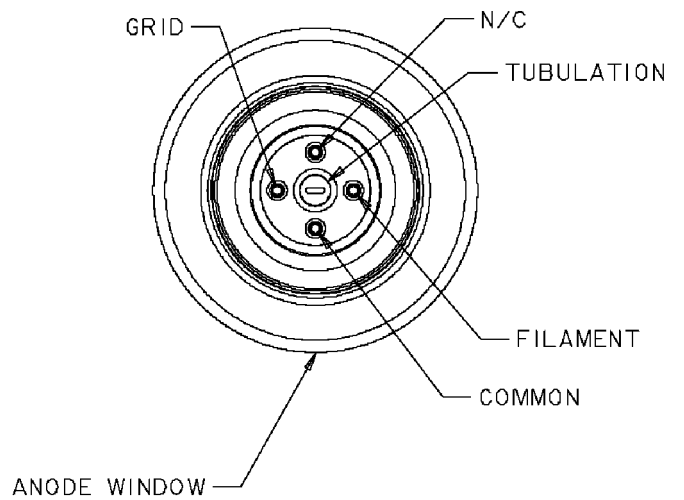

V-160 GRID CHARACTERISTIC

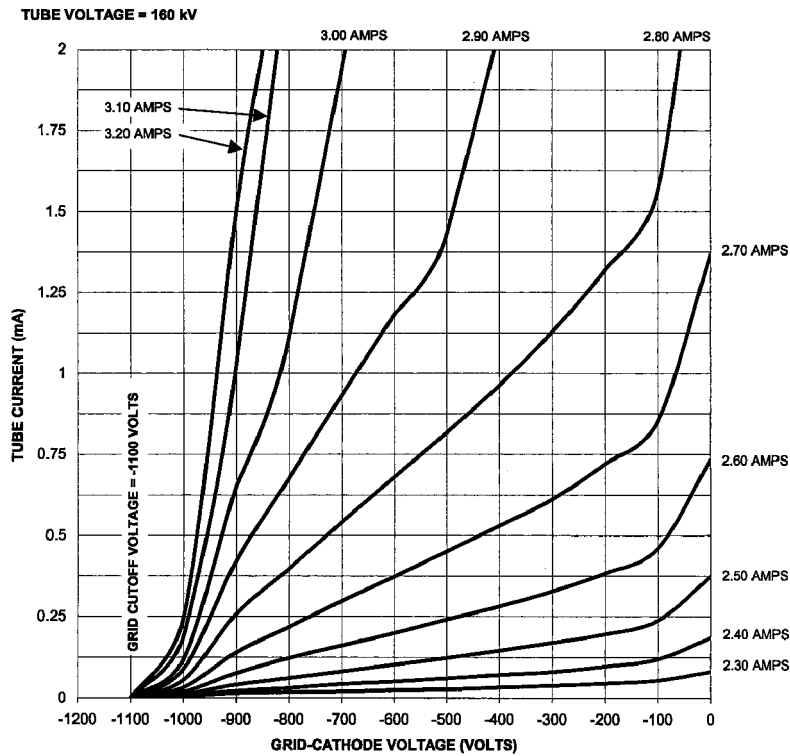

V-160 Grid Pulse Rating

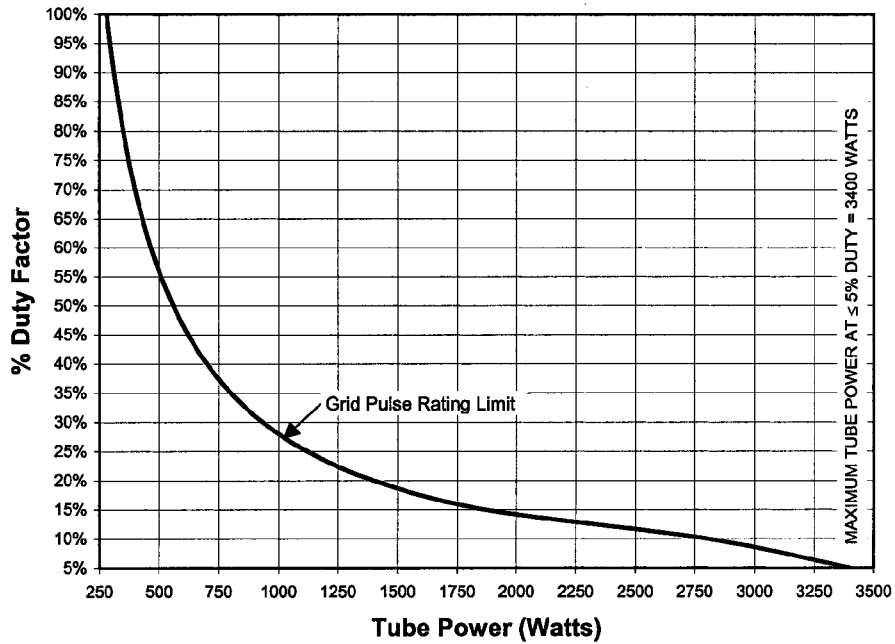

Notes:

1. This chart is valid for tube on times ranging from 1 millisecond to 1 second.
2. This chart is based on the following formula: (Tube Power) X (Duty Factor) ≤ 280 Watts average tube power. At duty cycles 5% or less, the maximum tube power must not exceed 3400 Watts.

V-160 DC EMISSION

