



**Product Description**

The NDI-350-23 is a 350 kV, oil cooled stationary anode metal ceramic x-ray source. This source is specifically designed for Non-Destructive Imaging Applications.

**X-Ray Tube Specifications**

|                                                |                                       |
|------------------------------------------------|---------------------------------------|
| Maximum Peak Voltage .....                     | 350 kV                                |
| Anode to Ground .....                          | 175 kV                                |
| Cathode to Ground .....                        | 175 kV                                |
| Focal Spot - EN12543                           |                                       |
| Small .....                                    | D = 1.9 mm                            |
| Large .....                                    | D = 3.6 mm                            |
| Cooling Medium .....                           | Oil                                   |
| Maximum Continuous Rating                      |                                       |
| Small .....                                    | 640 W with 14 Litre/min cooling flow  |
| Large .....                                    | 1600 W with 14 Litre/min cooling flow |
| Target Material .....                          | Tungsten                              |
| Target Angle .....                             | 20°                                   |
| Reference Axis .....                           | Perpendicular to port face.           |
| Radiation Coverage .....                       | 40°                                   |
| Loading Factors for Leakage Radiation .....    | 350 kV, 4.5 mA                        |
| Maximum Radiation Leakage .....                | 10 mSv/h                              |
| X-Ray Tube Assembly Permanent Filtration ..... | 4 mm Be                               |
| High Voltage Cable .....                       | R24                                   |
| Housing Type .....                             | V-320                                 |
| Weight (approx.) .....                         | 40 kg ( 88.2 lbs)                     |

**V-320**

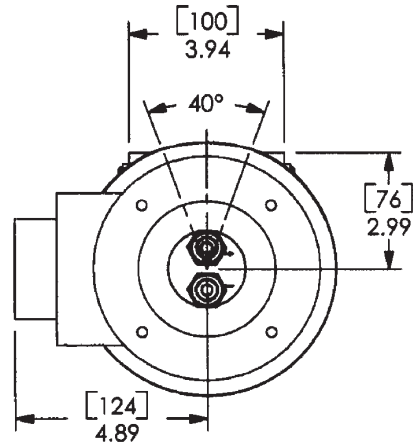
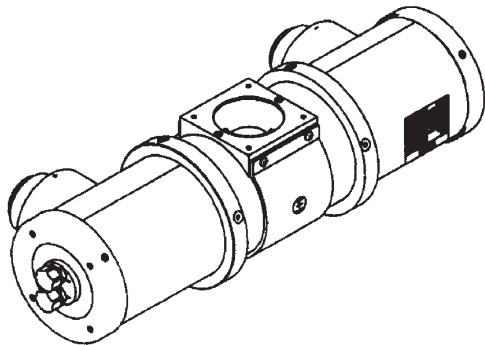
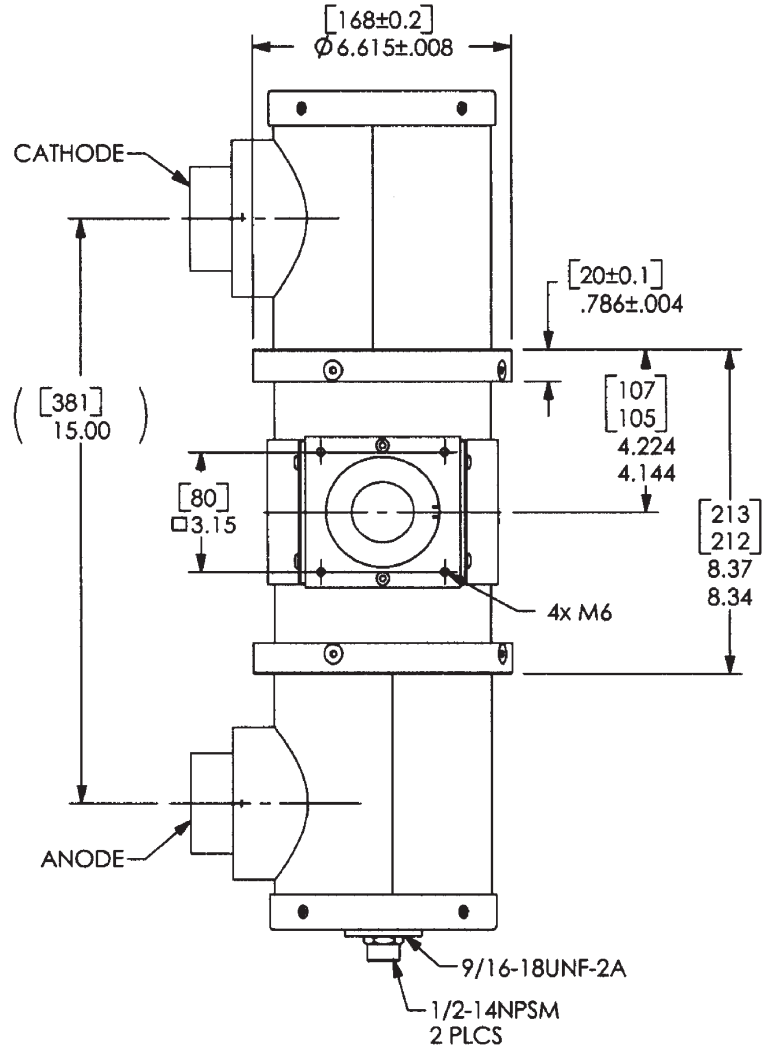
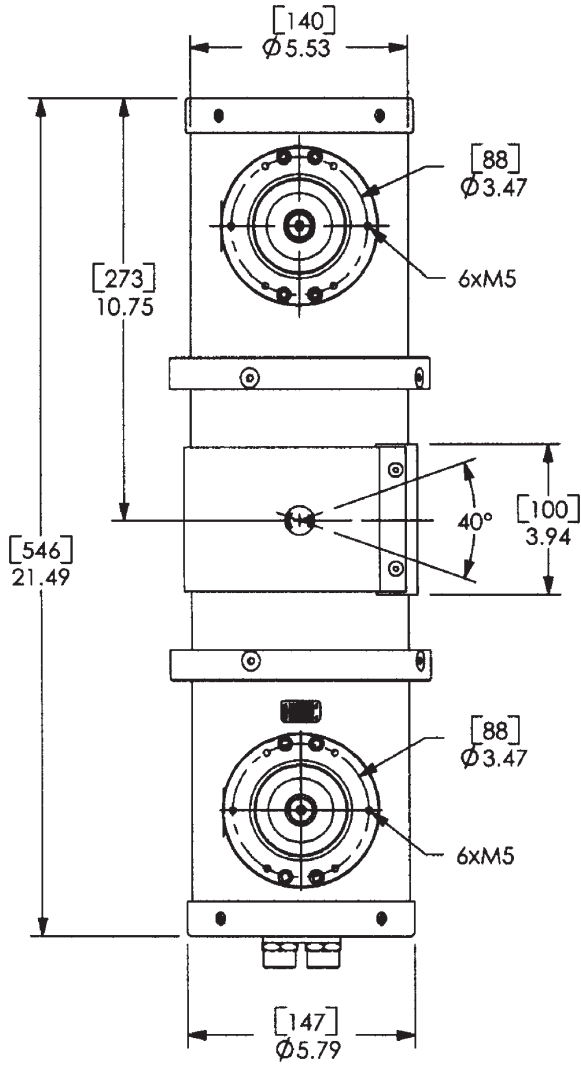

**150° Horn Angle**

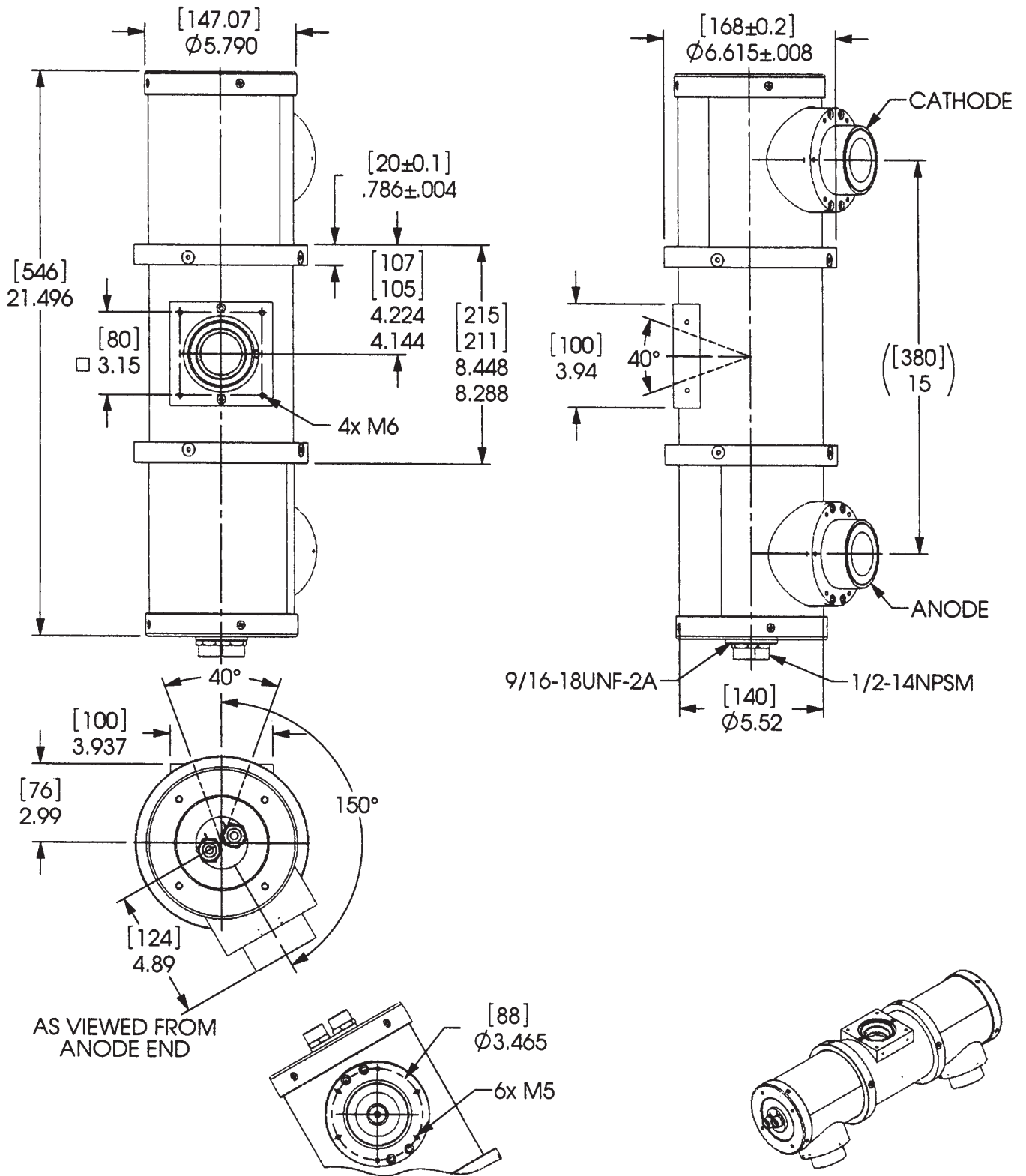

## **Instructions for Installation**

### **Connection of the x-ray tube**

The careful adjustment of the pressure gap and the use of the correct amount of silicone grease are extremely important. First, clean the rubber cone carefully with a lint-free cloth. Take specific care that the contacts are absolutely free of old grease or oxide layers. Use only pure alcohol for cleaning, no other detergents. Cover the entire cone with a thin film of the supplied silicone grease, apply a rope of approximately 3 cm of grease and spread it gently, avoiding the contact tip. The grease layer must be kept free of air bubbles, dust or dirt.

### **Cable terminal with mounting flange**

Rotate the mounting flange until there is a gap of 5 mm between the mounting flange and the tube. Remove the cable plug and carefully grease using the supplied high voltage insulating compound. Introduce the greased terminal plug parallel to the axis of the high voltage receptacle socket and advance until it stops.

### **Mounting flange**

Attach the mounting flange to the tube housing using the flange fastening screws making sure not to rotate the mounting flange from its setup position.

## **Operation**

### **General**

The control of the high voltage and the filament current as well as the design of the cooling unit is the responsibility of the equipment manufacturer.

### **High Voltage Connection**

Two terminal type R24 high voltage cables supply high voltage and filament current.

Two different methods of mounting the high voltage cable are available; appropriate mounting of the high voltage cables is included in the "Installation and Operation Instructions"

### **Cooling of the Anode**

It is the responsibility of the customer to ensure that the cooling medium flow meets the required cooling conditions. Insufficient cooling of the anode can lead to the destruction of the anode, therefore cooling must be switched on before the application of high voltage.

### **Control of Cooling Medium**

Flow, pressure, and temperature of the cooling medium at the inlet to the tube or the tube assembly must be appropriately monitored. High voltage must be terminated when the pressure or flow rate fall below the minimum level or when the temperature exceeds the maximum level. When the tube is switched off the coolant flow must continue for at least 2 minutes in order to protect the anode from destruction.

### **Quality of High Voltage Insulating Oil**

The anode must be cooled with X-Ray resistant high voltage insulating oil with at least 20 kV/mm dielectric strength and free of air.

**1600 Watts**

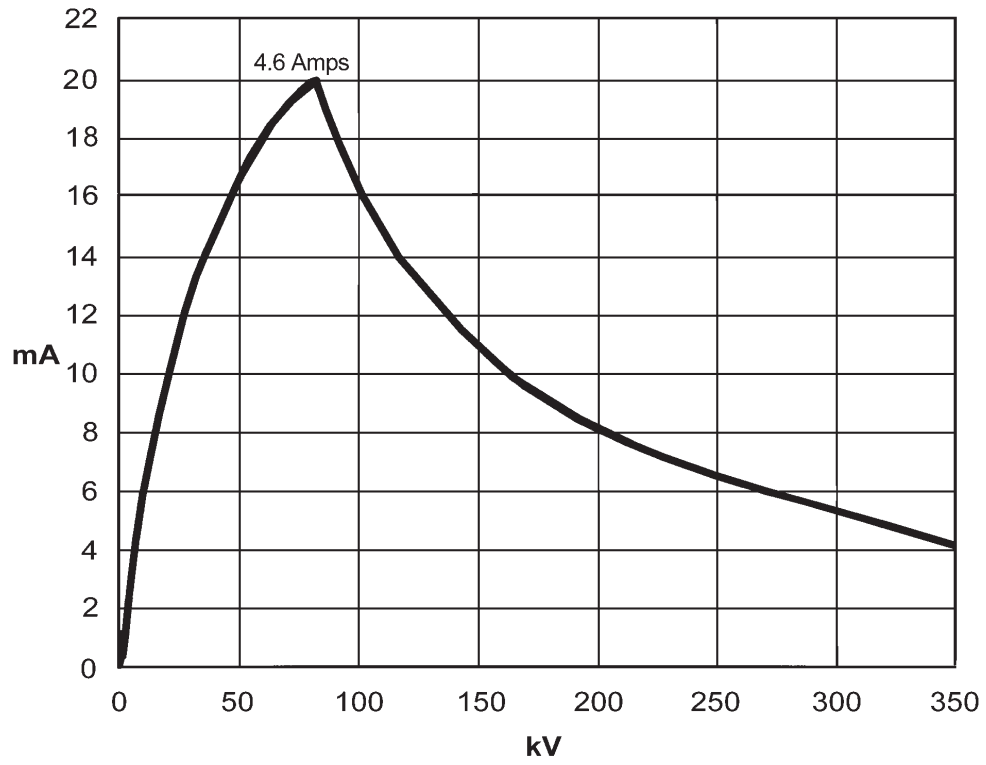

**640 Watts**

